

Historic South Australian Graves and Cemeteries



Conservation Guidelines

Prepared by
McDougall & Vines

Conservation and Heritage Consultants
27 Sydenham Road, Norwood, SA, 5067
and Hilary Hamnett and Associates

May 2004



Department
for Environment
and Heritage

CONTENTS

Page

1.0	GENERAL INFORMATION	1.1 Cemeteries and graves 1.2 Management 1.3 Regulation	1
2.0	RESEARCHING THE HISTORY OF A CEMETERY OR A GRAVE SITE	2.1 Title and Ownership 2.2 General Cemetery Records 2.3 Preparing a Narrative History of the Cemetery and Graves	2
3.0	UNDERTAKING A CEMETERY SURVEY	3.1 Obtaining Permission 3.2 Plan of Cemetery 3.3 On Site Recording of Graves and Monuments 3.4 Description of Condition 3.5 Description of Landscape 3.6 Botanical Assessment	3
4.0	HERITAGE VALUE	4.1 Heritage Status 4.2 Cultural Heritage Values 4.3 Natural Heritage Values	5
5.0	CONSERVATION PLANNING	5.1 Conservation Management Plans 5.2 Methodology and Process 5.3 Personnel and Funding 5.4 Appropriate Conservation Policies for Cemeteries	6
6.0	CARE OF STRUCTURES AND MATERIAL	6.1 Conservation Actions 6.2 Common Materials in Cemeteries 6.2.1 <i>Masonry</i> 6.2.2 <i>Metals</i> 6.2.3 <i>Timber</i> <i>What to do First</i> 6.3 General Cleaning of Headstones <i>Cleaning Headstones</i> 6.4 Conservation and Repair of Elements 6.4.1 <i>Headstones</i> 6.4.2 <i>Inscriptions</i> 6.4.3 <i>Plinths and Kerbing</i> 6.4.4 <i>Grave Floors and Ledger Slabs</i> 6.4.5 <i>Repointing of Joints</i> 6.5 Metal Grave Surrounds and Fences 6.6 Wooden Monuments 6.7 Painting and Protective Coatings on Stone 6.8 Removal of Graffiti 6.9 Drainage and Water Run-Off	9 11 13
7.0	CARE OF PLANTING AND LANDSCAPE	7.1 Conservation of Significant Landscape Elements 7.2 New Planting 7.3 Water Use 7.4 Maintenance and Weed Control 7.5 Invasive elements 7.6 Significant Tree Legislation 7.7 General Landscape Recommendations <i>Basic Landscape Maintenance</i>	18 21
8.0	NEW WORKS IN CEMETERIES	8.1 Infill 8.2 Reuse of Grave Plots 8.3 New Monumentation/Memorialisation 8.4 Introduction of New Structures	22

CONTENTS

Page

9.0	INTERPRETATION AND PROMOTION	9.1 Signage and Directions	24
		9.2 Information for Visitors	
		9.3 Friends Groups/Volunteers	
10.0	SAFETY AND SECURITY	10.1 Security	25
		10.2 Public Safety	
		<i>Personal Safety</i>	25
		10.3 Fire Precautions	
11.0	FUNDING	11.1 SA Heritage Cemetery Fund	27
		11.2 History Trust of SA	
		11.3 The Australian Government Envirofund	
		11.4 Non-Government Sources	
12.0	RECORDS AND REFERENCES	12.1 Cemetery Conservation Records	28
		12.2 Cemetery Conservation Publications	
		12.3 Technical Information	
		12.4 Relevant Legislation	
		12.5 Websites	
13.0	GLOSSARY OF TERMS	13.1 General terms	30
		13.2 Terms for Describing Grave Site Condition	

APPENDICES

1	Example of Grave Site Record	32
2	Typical Landscape Plan	33
3	Typical Tree Record	34
4	Typical Vegetation Management Record	35
5	Typical gravestone repair details	36
6	Heritage Act and Development Act Criteria	37
7	Tools and Materials for Gravestone Cleaning	38
8	Symbolism in Cemeteries	39
9	Plants Suitable for South Australian Cemeteries	42

1.0 GENERAL INFORMATION

1.1 Cemeteries and graves

Cemeteries and graves are important as both social and aesthetic elements of a community and they tell an important part of its story. Sometimes they are the only record of a group or settlement. Cemeteries therefore are commemorative landscapes of memory and history. Graves and monuments are part of the overall landscape of the cemetery and are important as individual sites of personal and family remembrance. They can demonstrate many aspects of a community's heritage including the development of an area, the genealogical and religious make up of the community, the original natural environment, the landscape design and botanical elements of cemetery design and even technical developments in areas such as ironwork and monumental mason's skills.

Cemeteries can be private or public and located within towns, close to settlements or in isolated locations. Often, small country towns or localities will have two or more historic cemeteries, each one associated with a particular church or congregation which was instrumental in the settlement of the district. They both contain and commemorate members of that community and by their planning and care they reflect the values and concerns of the society which founded them. Community memory is embodied in the monuments and gravestones, and cemeteries are an important part of any community's heritage assets.

Cemeteries can be purely historic in nature, or continuing in current use. The existence of historic cemeteries is threatened by general weathering and deterioration, lack of or poor maintenance, deliberate or unintentional vandalism, the conversion of dilapidated cemeteries to 'pioneer parks' or ill-considered reuse.

The issues that arise in caring for cemeteries involve both conservation and ongoing management. These guidelines are intended to assist in making appropriate decisions to ensure the retention of the heritage values and cultural landscapes embedded in historic cemeteries.

1.2 Management

Most cemeteries are the legal responsibility of Local Councils, churches or cemetery trusts, but there are other groups and organisations interested and involved in the care and maintenance of historic cemeteries, even if not formally responsible for them. These include community groups such as historical societies, service clubs, and also families and individual lessees or owners of grave sites.

For example, in Adelaide, the Adelaide Cemeteries Authority (created in 2002) has responsibility for the administration of West Terrace Cemetery, Enfield Cemetery, Cheltenham Cemetery and Smithfield Cemetery. The Anglican Church manages North Road Cemetery, St Michael's Mitcham Cemetery, St Mary's Morphettville and a number of other small cemeteries associated with parish churches.

1.3 Regulation

The legal framework for the management of cemeteries in South Australia sits within the *Local Government Act, 1934*, and the controls and requirements are cited as the Local Government (Cemeteries) Regulations, 1995. These regulations set out the responsibilities of the 'cemetery authority', which is '*the person or body for the time being responsible for the administration of the cemetery*'. The provisions of the regulations cover a range of issues including the physical care of the cemetery, the standards of interment within the cemetery and the powers of the cemetery authority in relation to the management of the cemetery itself.

For historic cemeteries or grave sites which are included as either State Heritage Places in the South Australian Heritage Register or as Local Heritage Places within Local Government Development Plans, any work within the cemetery which constitutes development will require approval from Local Government or the Development Assessment Commission. Most cemeteries within Local Government Development Plans are zoned as Special Use (Cemetery) and Council approval will be required for any work other than routine maintenance.

2.0 RESEARCHING THE HISTORY OF A CEMETERY OR GRAVE SITE

2.1 Title and Ownership

Crown Land Cemeteries - during the nineteenth and early twentieth centuries in South Australia, many areas of land were set aside in rural and urban centres and were dedicated as reserves for cemetery purposes. These general cemeteries were often divided into distinct denominational sections. Trustees were appointed, usually including representatives of the relevant denominations, and were charged with the care, control and management of the cemetery. On early land division maps a number of these cemetery reserves can be located, and though dedicated for cemetery use, some were never actually used for burials. A large number of cemeteries are not in use, but retain historic graves.

The ownership of some cemeteries situated on Crown Land has been transferred to the relevant Local Council, such as Willaston Cemetery to Gawler Council in the 1940s.

Church cemeteries - cemeteries associated with churches are usually included on the title of the church and managed by the church authorities. Many of these church cemeteries no longer accept burials, but retain their historic graves.

Private Cemeteries and lone graves - settlers in isolated areas occasionally established family graves on their own property. Individual graves were often dug to serve as burial places outside of dedicated cemeteries if these were some distance away. These cemeteries and grave sites are located on private land and not immediately accessible without permission of the owner.

Public access is freely available to all dedicated cemeteries. Where cemeteries are located on land enclosed by freehold land, a right of way is normally allocated.

2.2 General Cemetery Records

Records of burials and interments were initially maintained by appointed Trustees. Responsibility for general cemetery records now lies with Local Councils, or with the appropriate cemetery authority. Other records are held within church record groups, family histories, local libraries, archives, historical societies, the Society of Australian Genealogists and also the State Library.

Early records are often very fragmented and any that are located should be treated carefully and accurately transcribed to ensure retention of the valuable material.

A list of all cemeteries entered on the South Australian Heritage Register is available from the Heritage Branch of the Department for Environment and Heritage. Generally, Local Councils keep a record of cemetery sites within their boundaries.

2.3 Preparing a Narrative History of the Cemetery and Graves

A clear and concise history can be prepared for a cemetery if records exist and these can be cross checked with graves on site. Councils, churches and historical societies hold the majority of cemetery records. Other sources relating to deaths and burials include town histories, early newspaper articles and other published documents. Heritage Surveys undertaken for regions and towns in SA often identified cemeteries as significant places, and these can provide a starting point for information. A clear history of the establishment and use of the cemetery helps in understanding the relative importance of its elements.

3.0 UNDERTAKING A CEMETERY SURVEY

3.1 Obtaining Permission

Any survey of a cemetery should begin with obtaining permission from the relevant cemetery authority or owner or manager of the site. Special arrangements may need to be made for access to areas which are not readily open to the public, and there may be sensitive issues such as aboriginal burials or rare flora and fauna, which require appropriate consideration. Physical safety may also be an issue.

3.2 Plan of Cemetery

A cemetery survey will need a detailed and accurate plan of the grave sites in which interments have taken place. Many early cemeterys include a plan and all efforts should be made to locate one. Alternatively, it may be necessary to draw one up. Mark the individual grave sites on this, using a system of areas of lettered rows and numbered plots on a grid system if necessary, and include a North point and some indication of the scale. If periods of use are evident, notes to that effect could be made on the plan. In addition it is useful to accurately record the following information wherever possible: location of buildings (chapels, toilets etc.) structures including columbaria and other walls, retaining walls and significant changes of level, fences, infrastructure such as roads and footpaths, above and below ground services such as power, water supply, sewer lines and stormwater, taps, light fixtures, signage, seats, bins, shelters and any other items. Vegetation should also be recorded on plan with accurate locations and size of tree trunk and canopy and descriptions as indicated in Appendix 2. This plan should also include the date on which it was prepared, so that comparison of changed conditions over time can be made.

3.3 On Site Recording of Graves and Monuments

Individual grave and burial site recording should include a written description, a clear transcription of the inscription and, if possible, photographs of the grave site and the date on which the record was made. Consistency in the type of information recorded is important. Examples of appropriate forms for recording this information is given in [Appendix 1](#). This information should also be cross referenced to the cemetery plan. No material such as chalk or flour should be used to make the inscription more legible, as this will leave damaging residue. It is also not recommended that rubbings of grave inscriptions be used as a method of recording information, as this can damage the stone and details of the inscription. Use up-to-date technology to record monuments wherever possible. For instance, a digital photograph of a slate gravestone with a difficult to decipher inscription could have the inscription superimposed (typed on the photo on the computer) when the grave is recorded. [Appendix 4](#) lists the symbolism used on monuments in historic cemeteries.

3.4 Description of Condition

A clear assessment of the current physical condition of each grave site needs to be part of the recording process, with photographs highlighting all elements of the current appearance of the grave site, and wherever possible, the causes of any deterioration. This assessment of current condition should be included on the record sheet. The Glossary (section 13) gives a range of descriptive terms to assist this process.

3.5 Description of Landscape

The landscape of a cemetery can be an important part of its heritage value. The existing elements of the landscape should be recorded including any early planting, trees and shrubs, patterns of planting, invasive vegetation, notable plants and any missing elements where original planting schemes have been interrupted. The description should also include elements such as hedging, fences, walls, shelters, seats and other structures, which should be located on the cemetery plan.

3.6 Botanical Assessment

A more careful botanical assessment of the species within the cemetery will assist in determining the environmental value of the plants within the area. (A typical record sheet is provided in [Appendix 4](#)). Where necessary, an experienced botanist should be consulted to determine whether any indigenous species are located within the cemetery boundaries and the Conservation Status of

these as determined by the [National Parks and Wildlife Act 1972](#). Introduced species should be carefully assessed to determine if any of these form an important part of the planned planting in the cemetery, and if these have symbolic landscape value. [Appendix 9](#) provides a list of typical species used during the nineteenth and twentieth cemeteries in Australia and [Appendix 8](#) notes the symbolic meaning of various plants and flowers.

Some introduced plants, both native and exotic, may be considered environmental weeds and the status of these should be checked to determine appropriate actions. A list of Proclaimed Plants in South Australia can be obtained from the Animal and Plant Control Commission.



Blinman cemetery before essential maintenance was undertaken



Blinman cemetery after maintenance (2003)

4.0 HERITAGE VALUE

4.1 Heritage Status

Within South Australia there are cemeteries of both State and Local Heritage value. Cemeteries may also have community or family value. In some cemeteries individual grave sites are sometimes separately listed due to their specific heritage value. Local Council or the Heritage Branch, DEH, can advise of the status of any cemetery or site.

It is important to understand as much as possible about heritage values so that you can determine priorities and make the most effective allocation of resources.

4.2 Cultural Heritage Values

Assessment of the heritage value of a cemetery is a necessary step when planning any conservation work. For both State and Local Heritage Places, cultural heritage value is measured by criteria. These are included in the [Heritage Act 1993 and the Development Act 1993](#). If a cemetery is to be nominated for heritage listing, the relevant criteria should be used as the basis for assessment of heritage value. The two sets of criteria are set out in full in [Appendix 6](#).

In order to determine the cultural heritage value of a cemetery, consider the following aspects:

- The history of the cemetery and its place in the development of the area
- Its monuments and design in terms of its history
- The aesthetic and architectural quality of the monuments and structures,
- The importance of the types of stones and other materials used in the cemetery,
- The way in which the cemetery and its graves reflect the social structure and values of the community it commemorates,
- The spiritual values it embodies
- Its landscape and design qualities.

4.3 Natural Heritage Values

Many cemeteries contain indigenous vegetation, either naturally occurring or planted, which can make a significant contribution to the natural heritage value of the place, especially in combination with cultural heritage. Natural Heritage is valuable because it is a biological and/or geological resource, may be of scientific and/or aesthetic importance and helps to connect us to the natural history of the land.

[The Australian Natural Heritage Charter](#) recognises 'existence value' which implies not only the 'life-support value' of natural systems but the 'enrichment of human experience derived from the natural world' ([Guidelines for Cemetery Conservation National Trust of Australia \(NSW\)](#)). It is also important to recognise the contribution a plant association can make as habitat for native fauna. Poor management of existing natural systems can contribute to the degradation of cultural values as well as the intrinsic natural values by reducing the richness and diversity of the experience.

To determine the natural heritage values ask the question "why is the place important?" and consider the following criteria, although there may be more:

- Biological diversity – does it have diverse species, ecosystems or biological communities, rare or endangered elements, particular species?
- Existence value – does it have value beyond human social, economic or cultural values
- Geodiversity – does it have unusual hydrological systems, fossils, earth processes, landforms
- Scientific – does it help others understand this type of place; can it contribute to scientific understanding?
- Aesthetic – is the design inspirational, evocative, of a grand scale, symbolic, represented in art, have sensual qualities including sounds and smells?

5.0 CONSERVATION PLANNING

5.1 Conservation Management Plans

A Conservation Management Plan should be prepared before any major works are undertaken in an historic cemetery. This will then provide a framework for the priorities for conservation activities. Conservation within a cemetery will usually involve both the cultural and natural environment.

The aim of conservation in a cemetery is to maintain the area, its landscape and its monuments in good condition, while still retaining its character, evidence of age and all important built and natural elements. Conservation works should not be about improvement, but about retaining the significance of the cemetery itself. It is not intended to make monuments look new or 'improve' them, rather to ensure that they are maintained appropriately. It is important that the history of the cemetery be easily seen when visited. After works are completed in any particular area of a cemetery, it should still be able to be seen that the monuments reflect the period of time since burials first occurred in the graveyard. The natural and imposed historic landscape should also be intact and understandable.

Cemeteries are an expression of community including the varied cultural beliefs that make up the community, as often cemeteries contain burials from different ethnic and religious groups with diverse burial customs. Policies should be sensitive to this and reflect the significance and expectations of various cultural groups.

All conservation works should be recorded with written descriptions and photographs, both before and after whenever possible. This documentation will ensure that any responsible cemetery authority in the future will have a clear record of past works.

It is sensible if only essential maintenance is undertaken until an informed decision about policy for the cemetery has been made, and before the site is disturbed in any way. (Acceptable initial work is set out in [Section 6](#) and in the box 'What to do First'.)

It is also good conservation practice to monitor the results of work in the cemetery, and to review and adapt the Conservation Management Plan as required. Some actions may not have the expected results.

5.2 Methodology and Process

The accepted methodology for preparing a Conservation Management Plan is included in the *Burra Charter*, prepared by Australia ICOMOS, (www.icomos.org/australia/) and the principles in the charter apply to conservation of the cultural values of cemeteries. Detailed guidelines for the preparation of conservation plans are outlined in J S Kerr, *The Conservation Plan: A Guide to the Preparation of Conservation Plans for Places of European Cultural Significance*, National Trust NSW, 2001. Guidance for identifying, protecting and managing the natural heritage values of a place is provided in *Protecting Natural Heritage – using the Australian Natural Heritage Charter Second Edition 2002*. This handbook provides an excellent manual for developing conservation policies which will retain and manage natural heritage values. It can be downloaded from the Australian Heritage Commission website - www.ahc.gov.au/publications/pnh/.

Reference to these documents will provide some idea of the scope of a Conservation Management Plan for a cemetery which involves both cultural and natural heritage.

The logical and necessary steps in preparing and implementing a Conservation Management Plan are:

- Assess the cultural and natural heritage values of the cemetery
This will include assessing the physical condition, researching its history, contacting people or groups with an interest in the place, and finding out as much as possible. This is to ensure that there is enough information on which to base a statement of the natural and cultural heritage values of the place

- Develop conservation policy for all elements of the cemetery
Policy must be based on the recognised heritage values of the place
- Determine conservation processes and management strategies to fulfil the policies.
Processes and strategies should take into account the resources of the responsible managing authority
- Implement conservation strategies and management processes in accordance with the policy

These steps are equally relevant to places of all sizes and complexity, and need to be agreed on and written down prior to any works being undertaken.

5.3 Personnel and Funding

Where possible the preparation of a Conservation Management Plan should be undertaken with the assistance of an experienced person with appropriate professional qualifications. These will include historians, conservation and heritage consultants, landscape architects or environment consultants.

The Heritage Branch of the Department for Environment and Heritage has examples of cemetery Conservation Management Plans to provide a guide to the scope of such a document.

Funding for the preparation of Conservation Management Plans may be available from a variety of sources including the State Heritage Fund, the Heritage Cemetery Fund, Local Council heritage funds and the Natural Heritage Trust Bushcare Program. The History Trust of SA should also be approached if the Conservation Plan will lead to interpretation and care of records.

5.4 Appropriate Conservation Policies for Cemeteries

Policies should aim to cover the following issues, where relevant:

- Retention of the heritage values of the cemetery
- Conservation of the cemetery's historic physical elements:
 - Retention of all historic monuments
 - Relocation of monuments
 - Re-erection of broken fragments
 - Inscriptions
 - Plinth repairs and reconstruction
 - Kerbing and grave fencing
 - Grave furniture and ornaments
 - Maintenance of landscape features
- General Maintenance and ongoing works
 - Re-monumentation
 - New inscriptions and memorials
 - Reuse of graves
 - Painting of structures
 - Paths and drainage
 - Seating, fencing and gates
 - Water supply, standpipes and taps
 - Irrigation where appropriate
- New Works
 - Columbaria and Lawned Areas
 - Seating, fencing and gates
 - Landscaping and paving
 - New graves in existing historic areas
 - Reinstatement of landscape features

- Interpretation and Signage
 - Design and location of signs
 - Marking of graves and locations
 - Publicity and information
- Ongoing Responsibility and Management
 - Maintenance and works protocols
 - Care of cemetery records
 - Research and recording
- Conversion of cemeteries or areas within historic cemeteries



6.0 CARE OF STRUCTURES AND MATERIALS

6.1 Conservation Actions

The conservation of monumental masonry and graves within a cemetery is dependent on a range of issues including the materials of the monument, its current condition, the context and setting of the monument and general requirements for cleaning and repairs.

The guiding principle for conservation works in cemeteries should be that established by the Burra Charter:

***Do as much as necessary
but as little as possible***

Conservation can be a range of actions from stabilisation through to complete repair. Once a headstone or other cemetery element is damaged, repair should take place as soon as possible to prevent further deterioration. Detailed instructions for care and maintenance should be developed in a Conservation Management Plan. It is helpful if recommendations are prepared for individual significant graves as well as general guidelines for conservation works.

Wherever possible, existing materials and methods of construction should be used. Only badly damaged elements should be replaced with new materials.

Personnel - Conservation work for monuments and graves varies in complexity and will often require the input of an experienced tradesperson or mason. However, basic maintenance and repairs can be carried out by volunteers working carefully to sensible instructions, with the aim of retaining original materials and appearance. Training should be given and insurance cover should be in place before any volunteer labour is used.

'**What to Do First**' (see p. 11) gives some guidance for appropriate initial works.

Removal of elements - Many elements are often removed from graves, usually because of deterioration or in the interests of 'tidiness'. All elements of a grave are significant and none should be removed. This includes headstones, footstones, fences and railings and any other original elements such as vases or flower holders.

Staging of Works - It is recommended that a staged program of general maintenance for existing graves, based on the assessments provided as part of a survey of the cemetery be developed and implemented as time, money and labour are available. This will be particularly useful if volunteer labour is involved, as tasks can be assigned as willing workers become available.

Information on the requirements of the graves and methods of care and maintenance could also be passed on to families who regularly tend their graves currently.

In the short term, the approach recommended for initial works in the '**What to Do First**' box should be undertaken.

6.2 Common Materials in Cemeteries

6.2.1 Masonry

Marble - Most of the marble used in graves in South Australia is Italian Carrara marble which is fine grained and greyish. Monumental masons imported this to Adelaide from the 1860s. Angaston marble is sometimes used, particularly for kerbing and surrounds, and is whiter and more coarsely grained than the Italian marble. Red dust can turn white marble pink.

Sandstone - Sandstone was also used for headstones. However, most sandstone in cemeteries is used for kerbing or railing blocks or as plinths for marble headstones. Sandstone headstones are susceptible to weathering and erosion.

Granite - More recent graves use black or pink granite for headstones, and this is highly polished. Some earlier monumentation in the form of columns and obelisks is in grey granite.

Slate - The earliest headstones in most cemeteries particularly near quarry areas were cut from slate, usually Mintaro or Willunga slate. The early slate headstones generally show serious delamination and deterioration, often where rising damp is an issue.

Concrete - Concrete is used in a range of locations, usually as a base for kerbing and as the top ledger of a grave. It has more recently been used to repair damaged headstones inappropriately.

6.2.2 Metals

Most metal work in cemeteries is either cast or wrought iron and is used for grave railings and fences. In some early cemeteries in South Australia, particularly Lutheran Cemeteries, there are some ornate cast iron crosses still in existence and some cemeteries retain plate iron headstones. Some grave fences are constructed in rolled ribbon steel and date from the early 1900s.

Lead is used for applied lettering for inscriptions and also as a filler to hold headstones in plinths.

Other metal materials may include zinc or bronze sections to monuments or fences.

6.2.3 Timber

Timber is sometimes found in SA cemeteries as fences around graves or as simple wooden grave markers, usually crosses. Due to the variety of causes of deterioration of timber – moisture, rot, termites, fire, accidental impact and vandalism little timber monumentation remains intact in historic cemeteries.

WHAT TO DO FIRST

BASIC MAINTENANCE AND INITIAL CONSERVATION MEASURES FOR GRAVE SITES

There are some things that can be done before a Cemetery Conservation Management Plan is prepared. These basic tasks will ensure that no further deterioration occurs and will keep things in place until more complicated works can be arranged

Location and collection of fragments. Pieces of any damaged headstone or part of a monument such as lettering, tiles and other fragments should be collected together and kept temporarily at the relevant gravesite until appropriate repairs can be done. If there is any risk of further damage on site, the fragments should be securely stored, clearly labelled and their location identified, for later reinstatement

Temporary placement of broken monuments. Broken pieces of headstones should be collected and laid on the grave with the inscription upwards. These pieces should be set on a sloping bed of coarse aggregate to allow water run-off, and also allow the inscription to be read by visitors. More permanent conservation should be carried out as soon as possible

Basic weeding. Weeds and invasive vegetation should be removed carefully by hand, poisoned with a herbicide which does not damage stonework, carefully trimmed or mowed or a combination of these methods. Any specifically planted grave plants, such as bulbs or roses, should be carefully protected and retained

Excavation to expose plinths or kerbs. Any soil or debris which has built up around the base of the grave or its surrounds should be carefully removed, using hand tools, to reduce sources of damp and deterioration. Ground levels should slope gently away from the base of graves. Check any removed soil for grave fragments such as lead lettering

Chocking beneath unsupported plinths and kerbs. The gaps beneath unsupported masonry of headstones and grave surrounds should be chocked with coarse stone and gravel bound with a stiff mortar made from low alkali cement. This will provide some resistance to further erosion, until major conservation works can be done

Filling to counteract erosion. If erosion has occurred the ground surface should be built up with an outward sloping surface to direct water run-off away from the base of graves and prevent further erosion and undercutting

These notes are based on recommendations made by David Young, Heritage Consultant and Conservation Scientist, for conservation at West Terrace Cemetery in 1997.

6.3 General Cleaning of Headstones

The value of cleaning soiling from headstones should be carefully weighed against the loss of patina and character that is an important part of an historic cemetery. The usual causes of soiling of headstones are:

- Dirt, dust and grime from urban pollution
- Soot or smoke staining
- Organic growth (algae, fungi, lichens, mosses)
- Other stains from metals, oils or other materials
- Efflorescence from soluble salts in the stone

The decision to clean headstones must balance the 'new' appearance against the necessary care of the headstone. No headstone which is particularly brittle or fragile should be cleaned. If the stone is cracking, splitting, flaking or scaling, or has a grainy surface, do not attempt to clean it.

The process should involve initial brushing with a soft bristle brush to remove loose, dry material. This may be sufficient to dislodge dust and loose dirt or efflorescence. If further cleaning is required the next step should be generous wetting with clean water and scrubbing with a soft bristle brush. No wire brushes or metal tools should be used. Cleaning should start from the base up to avoid streaking of dirt over uncleaned sections, and the whole of the headstone should be cleaned in the same way.

A non-ionic detergent or pH neutral soap may be useful in some cases of heavy soiling, but tests should always be undertaken first, to ensure that no discolouration or filming results from washing with a detergent solution. Foto-flo, non-ionic detergent, a Kodak product used by photographers as a degreasing agent is excellent for washing headstones, and is available from photographic supply shops. An acceptable alternative is dishwashing detergent made for sensitive skin, the mildest formula available. Either form of detergent should be made up to a very weak solution of around 10ml (one teaspoon) per 10 litre (bucket of water).

Household bleach should **not** be used to whiten marble or remove moss and lichen, and no other acidic or corrosive chemical cleaners should be used.

Stone headstones, particularly white marble ones, often have biological growth on them. Where the fungi, lichen, moss or mould does not obscure information, this will generally cause little damage and cleaning may not be necessary. If the headstone is covered in lichen or moss which is causing deterioration of the stone and cannot be removed by brushing, an appropriate biocide can be used.

Biological growth should be removed when:

- The monument is greatly disfigured by lichen or moss growth
- The monument is being damaged by the growth, if sandstone is deteriorating or lead lettering is being dislodged
- Inscriptions are obscured and made unreadable
- The growth is across areas which need conservation repairs such as repointing

Remember:

- It is important to test any cleaning process on a small, hidden portion of the stone first.
- No wire brushes or metal tools should be used.
- Do not sandblast or pressure clean a gravestone.

A list of appropriate cleaning materials and equipment is given in Appendix 7

If in doubt, ask.

CLEANING HEADSTONES AND MONUMENTS

It is possible to remove some long term dirt and organic growth on headstones if it is damaging the stone or inscriptions. Remember, though, that old headstones do not have to be shiny and new-looking after cleaning. They should retain some evidence of their age and character. The following approach is considered the best:

- Carefully check the condition of the headstone or monument. If the stone is cracking, splitting, flaking or scaling, or has a grainy surface, do not attempt to clean it. If it is subject to rising damp and sounds hollow when tapped, it should not be cleaned and should be handled carefully
- Decide what the soiling is that you want to remove, and indeed whether it should be removed at all. The usual causes are:
 - dirt, dust and grime from urban pollution
 - soot or smoke staining
 - organic growth (algae, fungi, lichens, mosses)
 - other stains from metals, oils or other materials
 - efflorescence from soluble salts in the stone
- First brush gently, using only as much force as the condition of the headstone would indicate. This may be enough
- Start any cleaning by using the most gentle method, soaking the headstone with clean water to soften the dirt and grime
- Continue rinsing with clean water and gently brush with a soft bristle brush (natural or nylon bristles) using a circular motion. Organic growth can be gently prised off with wooden skewers or an icy pole stick. Do not use metal scrapers
- Always start at the bottom and clean upwards to avoid any streaking or staining downwards. Rinse regularly while cleaning and keep brushes clean
- If after patient work this does not move the soiling sufficiently, choose an appropriate material to assist with the cleaning. Start with a weak solution of non-ionic detergent like Kodak Photo-Flo (from photographic suppliers), or use the mildest dishwashing liquid available. Test first to make sure no film or residue is left on the stone
- Test before you apply any cleaning materials. Do this in an inconspicuous small area on the headstone. Always thoroughly wet the monument with water before applying any chemical cleaning solutions. This prevents excessive penetration into the stone and softens the stains or soiling
- Finally, rinse thoroughly with clean water to remove all residue which might cause blotches or further staining. Cleaning solutions must not dry on a monument
- If you need to use stronger cleaning methods get some expert advice. Make sure you use the most effective cleaning method for each case. One method won't solve all problems, and could damage stonework further
- **Remember, if you are in any doubt, get some expert assistance**

6.4 Conservation and Repair of Elements

6.4.1 Headstones

Leaning and falling monuments - Headstones or other monuments on graves often show some degree of tilting or leaning. This is not a problem unless the stone is in danger of falling due to its own weight, or the angle of leaning invites a push. It is appropriate to leave headstones which are only tilting marginally. The cause of tilting includes root growth, collapse of underground structures, variations in soils or clays, or inadequate drainage. If straightening is required, a secure base should be created using compacted fill of firmly tamped soil, sand and gravel which will enable adequate drainage. In all cases it is essential that the ground surface be adjusted to slope away from the monument. Headstones should be monitored to determine whether they are tilting further and need support.

The same approach should be used to straighten headstones still firmly set in sandstone plinths. Any repairs to plinths should be carefully undertaken in a lime mortar (one part lime putty to two parts fine matching sand). Repairs to sandstone should use sand in the mortar which matches the stone in grain size and colour as closely as possible.

Disassembled monuments (not broken) - Monuments which have been knocked or fallen but not broken should be reassembled carefully and made stable. This may require dowels or carefully sited mortar or adhesives of appropriate composition. Ensure the base or plinth is stable before resetting headstones and other elements.

Broken Monuments or Headstones - If headstones, or monuments such as crosses, have broken above their base or plinth, these should be repaired using threaded stainless steel or nonferrous dowels and pins. Adhesives should be used to hold the sections and dowels in place. Epoxy resins pre-mixed with fillers are most effective. This type of work should be done by an experienced conservator or mason.

Alternatively, the headstone can be repaired using a back plate, smaller than the headstone but of the same material and thickness. This can be either adhered with an acrylic or epoxy glue, or fixed with bronze or stainless steel pins, making sure the pins are shorter than the thickness of the two pieces to be joined. Other methods include attaching a metal strip on the back.

If the repaired headstone has no base and can not be re-erected, it should be laid, but not stuck, on an appropriate sloping concrete or compacted gravel bed constructed in the grave top. It is important to keep it in the correct plot.

Cracking masonry - Masonry will crack due to pressure from misalignment or expanding metal dowels or fixings. Straighten the masonry element or remove any rusting metal and replace it with new fixings isolated from stone work by lead lining or fillers. Ensure any water run-off is directed away from the connection points of stone and metal fixings.

Spalling, fretting and delamination of stone monuments - This type of deterioration is almost always caused by rising damp or accumulation of corrosive salts or rainwater. Drainage and run-off must be improved and flaking stone removed or, where advisable, re-adhered with acrylic resin or stone consolidant. Expert advice is needed for this process

[Appendix 5](#) provides illustrated guidance for headstone repairs.

6.4.2 Inscriptions

Carved inscriptions should be generally brushed back and cleaned. Re-blackening could be undertaken if required, using lamp black and linseed oil. Recarving of inscriptions is not generally recommended, however, if the original inscription is illegible, re-inscription could be undertaken by a monumental letter cutter. The work should be guided by a clear and detailed photograph taken, if possible, well before the work becomes necessary. It is also necessary to add a footnote or inconspicuous plaque which notes the fact that re-inscription of the original has taken place, and the year noted. Alternatively a plaque fixed to an inconspicuous part of the grave site can note the original inscription which had been transcribed.

Loss of lead lettering - Any lead letters which have fallen out of the headstone can often be found close by on the ground. These should be retained and carefully replaced in the appropriate position. Replacement of missing lead lettering with new letters requires expert assistance, and may not be necessary if the inscription can still be clearly read.

Fretting of inscriptions on stone monuments - This is due to natural weathering, delamination of slate or rising damp. Ensure that all sources of moisture penetration are reduced or removed completely. Record any deteriorated inscriptions before they are lost entirely.

Adding new lettering - No new lettering should be added to original inscriptions. Any new inscriptions for new interment in family graves should be separated from the original and clearly marked as new with a current date.

6.4.3 Plinths and Kerbing

Cracked or broken plinths - Broken plinths may also be dowelled together or repaired with lime mortar, following the procedure recommended for headstones. Refer to Appendix 5.

Replacing Plinths - It is possible to replace badly damaged and deteriorated plinths with appropriately cast concrete plinths and reset headstones into them, ensuring separation of the stone from the concrete by the use of fillers. This will ensure the salts in the cement do not damage the stone.

Movement of kerbing - Any sandstone, slate or marble kerbing which exists should be carefully straightened if required, and it should be ensured that the ground level is sufficiently low as to not cause pressure on the kerbing or the blocks which hold it. A mixture of sand, gravel and soil can be used to create a secure base under areas of kerbing and surrounds which have moved out of original alignment.

Any simple, clean cracks in the masonry kerbing should be repaired with a lime mortar of one part lime putty to two parts fine washed matching sand.

6.4.4 Grave Floors and Ledger Slabs

Concrete and aggregate floors - Often early graves are covered with concrete slabs, creating a floor which is often covered in gravel or aggregate. Occasionally the concrete floors are tiled, usually with plain white tiles. Concrete floors often fracture and frequently cave in due to subsidence below. Where possible pieces of the concrete floor should be raised to level by packing earth or gravel beneath. This means they can be retained in situ and not replaced. However, if the floor is badly broken, it will need to be replaced and the new floor should be at the same level as the original. Once all elements of the grave topping or tiling have been removed, the grave should be filled with earth and compacted gently. A new level floor of 40-50mm depth of concrete should be installed with an allowance for expansion around the edges if kerbing is in place. All elements of the existing grave including kerbing and headstones should be protected during the reinstatement or replacement of the concrete floor. Ensure that the new concrete floor drains appropriately and water does not collect on the grave top. Low alkali type cement should be used for the concrete. Once the top has cured the aggregate toppings or tiling should be replaced.

Tile repairs - Repairing tiled grave tops or ledgers is difficult and should be undertaken with care. Accurate matching should be the aim, but this may be difficult. Each case will need to be assessed on its merits and specialist advice should be sought if necessary.

Grave Floor/Topping - Where grave floors have subsided or broken, the grave itself should be filled with compacted material (gravel and filling) and used to support the sections of the grave top which remain. If a new grave top must be laid, this should be undertaken very carefully after filling of the grave site. The fill which is used to even up the surface must not allow water to pond beneath the

surface and the existing surface should be reshaped to enable water to drain away. The appropriate topping, usually white or grey gravel, should be reused. If there is evidence of other topping, this should be matched. Extra topping can be added to level off grave floors which have sagged a little, but not collapsed.

Drainage holes through the kerbing or grave surrounds should be cleared and made workable.

Ledger Slabs - Ledger slabs sit on top of grave toppings, often resting on the kerbing. If these have moved and are in one piece, they can be gently lifted and replaced in the correct position. Kerbing may need to be reinstated to its original levels to support ledger slabs securely. It is recommended that any packing should be solid and inert. Timber is not appropriate as it swells and shrinks with moisture changes.

6.4.5 Repointing of Joints

All pointing of joints between stones in the monument must also be made sound to prevent water penetration. Any jointing should be as fine as possible and match any existing on the grave or one similar in materials and design. An appropriate mortar mix for repointing is a relatively dry mortar mix of one part lime putty : to two parts fine washed sand. All mortar for fine stonework or rubble stonework should match the existing wherever possible in colour and texture. When any repointing is done all excess mortar should be immediately removed from the face of the stonework, and not smeared across the stones.

6.5 Metal Grave Surrounds and Fences

Rusting of cast and wrought iron memorials and grave surrounds - Many railings and fences around nineteenth and early twentieth century graves are constructed in cast iron or wrought iron, often unpainted. This ironwork needs protection against corrosion, and in most cases a routine application of fish oil (Wattyl Killrust Fishoilene in a 50 : 50 mix with mineral turps to help penetration into joints) or other metal preservative will inhibit further rust. The railings should be gently brushed back with a bristle brush to remove loose, flaking iron scales prior to the application of any preservative surface. This process should be undertaken in dry warm weather. It is not recommended that the grave surrounds be painted if they are currently unpainted.

Dislodged iron railing - An iron railing or fence should only be disassembled if the blocks on which it stands require replacement. Loose sections can be strengthened by neatly tying with soft galvanised wire.

Broken cast iron railing - It is possible but complex to recast broken sections of cast iron railings and expert advice should be sought if this is required. Local foundries can assist in the casting of new elements. Callington Cast Iron is one such foundry, others are listed in directories.

6.6 Wooden Monuments

Sources of moisture should be eliminated near wooden monuments and structures. Any fungal or insect attack should be assessed by an expert and treatment which is the least damaging to the element be determined. Any cleaning of timber monuments should be done as gently as possible and no pressurised systems should be used. Any repairs should be undertaken in well seasoned timber of the same species or an appropriate match. Seek advice from a good carpenter, builder or conservation architect as to the correct timber. New work should be identified with a stamp, carving or plate with the date of the new work.

6.7 Painting and Protective Coatings on Stone and Iron

No protective coatings should be used on old stone or masonry. If any original paint can still be seen on the monumentation this should not be removed with cleaning as this is evidence of original finishes. To retain the early character of an historic cemetery it is probably better not to repaint any sections including old iron work. This can be conserved as recommended in the section under metals in these guidelines.

6.8 Removal of Graffiti

Graffiti should be removed as soon as possible, both to discourage further graffiti and to minimise damage to headstones and other historic materials. Graffiti removal is technically complex and should be undertaken by skilled persons using appropriate techniques and materials. Generally, solvents can cause inks and dyes to spread further into porous stonework, while poultices draw the staining material out. Occupational Health and Safety requirements must be met when working with toxic chemicals.

6.9 Drainage and Water Run-Off

Graves can be easily undermined by erosion and headstones damaged by moisture penetration and rising damp. Often ground levels build up against early headstones and grave surrounds. Drainage away from grave sites and bases of monuments is essential to prevent any water damage, and earth and other debris should be cleared away from the base of graves. Effective site drainage systems should be in place in cemeteries to ensure moisture damage and erosion does not occur. These could be either simple swales and surface drains, or more complicated full storm water removal systems. The responsible authority for a cemetery should ensure that effective drainage is in place, but basic maintenance at each grave site can direct water away from graves and assist in keeping headstones dry.



7.0 CARE OF PLANTING AND LANDSCAPE

Cemetery landscapes can be designed or accidental. Some elements of cemetery landscapes are important parts of the heritage fabric of the place. Other elements are destructive and should be controlled to avoid damage to significant structures and grave sites. The landscape and context of the cemetery as a whole should be carefully analysed, preferably as part of a Conservation Management Plan, before any work is planned.

7.1 Conservation of Significant Landscape Elements

Layout - The layout of the cemetery, whether a simple grid in a small cemetery or a more elaborate plan with focal points, built structures, avenues and path systems, makes an important contribution to the character of the cemetery. Always aim to retain the original features of the layout where possible. A plan recording the landscape elements is a useful reference document (refer to Appendix 2). If any changes are required they should be made with minimum impact on the overall layout so as not to compromise the original character.

Existing plantings - Trees form an important part of the character of a cemetery. They help define the structure, provide shade and provide habitat for native fauna. Both native and exotic trees were traditionally planted, usually evergreen. If trees need to be replaced they should be of the same species as the original especially where they form avenues. Where trees are indigenous to the locality and their continued use is appropriate, it is preferable to use local seed sources.

Some traditionally used species are no longer considered appropriate for use in cemeteries. They may have invasive root systems that damage grave sites (e.g. *Casuarina glauca* – swamp sheoak) or may have seeds which self-sow (e.g. *Pinus halepensis* - Aleppo pine, *Olea europaea* – Olive and *Fraxinus spp* - ash) which also cause damage to monuments or compete with other desirable plants.

Due to the seasonal nature of plants, a twelve-month period of observation and recording should be undertaken before any work is carried out on plantings. Spraying or mowing could damage rare plants which contribute to the cultural as well as natural significance of the cemetery. These plants may also be a valuable botanical resource.

Existing native vegetation - Native vegetation is often found associated with cemeteries and makes a significant contribution to both the natural and cultural values of the place. They may contain examples of original ecosystems, include specimens of rare or threatened plants and provide habitat for native animal life. It is important to conserve these areas by preparing a conservation policy and conservation plan to ensure appropriate management techniques are used. As with introduced plantings, observation, recording and preparation of the conservation policy is required before any actions are undertaken. Particular care is required with herbicide spray which should be avoided within these areas.

There may be local people and groups who have specialised knowledge of the plants and management of the native vegetation in the locality of the cemetery who can be a valuable resource. Guidelines and checklists for preparing and implementing conservation plans can be found in the document *Protecting Natural Heritage: using the [Australian Natural Heritage Charter](#)*.

Where native vegetation is regenerating on graves, it may be inappropriate to retain it, especially if there are substantial stands of remnant vegetation elsewhere within the cemetery. If so, the vegetation should be removed from graves, especially trees and shrubs whose roots may damage headstones.

Where there are only limited patches of remnant indigenous vegetation, seed may be collected from the remaining plants and used to grow on seedlings for future revegetation in appropriate places within the cemetery, such as boundary screening. Once newly planted areas are established the self sown vegetation on the graves can, if necessary, be removed.

7.2 New Planting

Any new planting should be carefully considered. Issues such as existing species, design layout and location, the possibility of important elements becoming obscured, invasive damage to graves and surrounds, mature height and spread, and shading and water requirements must be taken into consideration before any uncontrolled new planting is undertaken. Many cemeteries are located in arid areas and lush vegetation would not be sustainable or appropriate.

Planting on historic graves is not an appropriate conservation action. If planting is appropriate around or close to graves, this should be only undertaken with species which have non-invasive compact root systems, (refer [Appendix 9](#) for suggested species).

The use of existing appropriate planting to provide cuttings or scions for continued use of the same species is often a good approach, as these will have proven suitable for the area.

[Appendix 5](#) includes a list of traditionally used cemetery plants. It is important to use these lists in conjunction with information on climatic conditions, soil suitability and potential weed problems.

7.3 Water Use

Although watering will be required to maintain some of the existing introduced plantings, a balance should be achieved between maintaining plantings and minimizing the use of water both to protect headstones and other artifacts and as good practice in minimal use of water. Indigenous plants should not require water other than for the establishment of new plants. If possible, grow indigenous plants from locally sourced seed which will be best adapted to local climatic conditions and soil types.

New plantings should be in zones of similar water requirement with areas of higher water demand located in contained areas away from graves.

If the cemetery has an automatic irrigation system, ensure that there is no overflow from sprinklers onto graves. Watering in the vicinity of graves should be discouraged and done only by hand. Plants in the vicinity of graves which are of significance should be protected but not encouraged or nurtured by watering and fertilisation.

7.4 Maintenance and Weed Control

Regular programmed maintenance avoids many problems. Weeds and other invasive vegetation must be carefully removed, preferably by hand, or using a selected low-toxicity herbicide. Mechanical weed removal is often damaging to graves and surrounds. Existing vegetation requires careful monitoring to ensure that planting does not cause any ongoing damage in the future. Bulbs which appear annually should be retained but controlled in appropriate areas, so that they become a positive landscape element.

The ground level can rise substantially over time and earth can cover masonry and the base of metal railings. This results in moisture damage to the stone or metal which is in constant contact with damp earth, particularly during the winter. The level of the adjacent earth should be carefully lowered around individual graves, paths should also be progressively lowered over time and inadvertent incremental build up avoided.

Mature trees which are an important landscape feature in some historic cemeteries create a large amount of leaf litter. While this has an attractive natural appearance on the ground and on the top of graves, it can cause serious problems of staining and raising of ground levels adjacent to stone and metal elements. Leaf litter and other organic debris should be regularly removed from grave tops and paths wherever necessary to prevent a build up of organic matter against stone or iron grave elements.

Refer to [Appendix 4](#) for a typical 'Vegetation Management Record' sheet.

7.5 Invasive Elements

Trees and bushes which have self sown within grave plots and are causing damage to graves should be carefully removed. Poisoning and gradual removal is often the best process, taking care to support any grave elements if subsidence occurs because of decay of substantial roots. Seedling trees should be removed as part of regular maintenance.

7.6 Significant Tree Legislation

Before any large trees are pruned or removed, check whether they are classified as 'significant trees' within the [Development Act 1993](#). Any activity that damages a 'significant tree' is development and requires approval from the appropriate authority.

The Development Act and Regulations have been amended to provide that a 'significant tree' is:

Any tree in Metropolitan Adelaide and townships in the Adelaide Hills Council with a trunk circumference of 2.0m or more. In the case of trees with multiple trunks, those with trunks with a total circumference of 2.0m or more and an average circumference of 625mm or more, measured at a point 1.0m above the ground level or

Any tree identified as a significant tree in the City of Adelaide, City of Burnside, City of Prospect or City of Unley Development Plans.

Further information about 'significant trees' can be obtained from Planning SA, Fact Sheet July 2003, [Information about protecting Significant Urban Trees](#). It should be noted that, while not currently applicable to regional areas of South Australia, it may become discretionary in the future.

7.7 General Landscape Recommendations

The landscape of a cemetery also includes the plan, paths and paving, seats, signs and shelters. The care of these elements should be included in a maintenance program. Materials used in the maintenance and repair of these elements should, where possible match the original or, where no longer available, be sympathetic. Incompatible modern materials should be used inconspicuously and only where absolutely necessary. Where deteriorated fabric requires the replacement of items, some of the original should be retained as reference.



BASIC MAINTENANCE AND INITIAL MEASURES FOR CEMETERIES LANDSCAPES

There are some things that can be done to protect the cemetery landscape before the Cemetery Conservation Management Plan is prepared. These tasks will ensure there is no loss of valuable vegetation or other landscape elements and allows time for careful assessment before more complicated works are undertaken, if required.

Wait, do nothing to the plants - If no records exist of existing or previous plants growing in the cemetery it is best to wait for twelve months before doing any weeding, removal or remedial work on plantings. Weed control may destroy valuable bulbs, annuals, perennials or remnant indigenous vegetation

Prepare a plan. - During this initial period, obtain or make a simple plan of the cemetery and record all the landscape elements. A typical plan will show all the main landscape elements including planting, structures, fences and services

Trees - Record the species, location, trunk size and canopy size on the plan. Keep a record of trees using a comprehensive form. It is important to note the spread of the tree canopy as this will affect the type and condition of planting growing underneath it. Bulbs may reappear once woody weeds have been removed

Significant trees - If the trunk circumference measured at one metre above ground level is greater than two metres, it may be a significant tree under the *Development Act 1993*, depending on the locality of the cemetery. Significant trees require Development Approval if they are to be removed

Observe and record plants growing in and around the cemetery - This can be a daunting task and may require the assistance of an experienced botanist or environmental consultant. Recording should take place at regular intervals throughout the year so that annuals and bulbs are recorded

Basic weeding - Once weeds and invasive vegetation has been positively identified and all existing vegetation recorded over a twelve month period

Grave sites - Carefully remove weeds preferably by hand, or poison with a glyphosate bioactive herbicide which does not damage stonework. Alternatively, carefully trim or mow or use a combination of these methods. Any specifically planted grave plants, such as bulbs or roses, should be carefully protected and retained

General landscape areas - These areas including hedges, avenues of trees, ornamental garden beds and lawns may be less sensitive than areas in proximity to graves. However, once the planting has been recorded it should be assessed as to its cultural and historic appropriateness and ease of maintenance (for instance, modern roses may be out of character). Remove weeds as for grave sites and prepare a plan to replace any inappropriate planting

Remnant native vegetation - Best bush management practices should be adopted.

Watering - Watering in the vicinity of graves should be discouraged and be done only by hand. Plants in the vicinity of graves which are of significance should be protected but not encouraged or nurtured by watering and fertilisation.

All activities associated with plant management should be recorded. This provides a useful document to assess the success or failure of methods, to plan a programme and to make the best use of available resources

8.0 NEW WORKS IN CEMETERIES

8.1 Infill

New graves in historic areas of cemeteries should preferably be in previously unused plots. New graves which are dug beside existing graves should be excavated with care to ensure that no damage is caused to the structure of the existing grave through subsidence or other movement.

Generally, if the following principles are followed, any new graves should not detract from the existing character of an historic area of a cemetery.

- New headstones should reflect the existing character of the area in which they will be located. Elements to consider are form, height, materials, colour, inscriptions and surrounds
- Generally, they should be of similar form and dimensions to those adjacent or close by. Simple designs are usually the most appropriate forms
- New headstones should not be higher than the general height of the headstones in the immediate area and definitely not higher than any significant monuments
- The colour of new headstones should not be darker than those adjacent, and so will be mainly white or grey in areas where there are predominantly marble headstones. Polished granite of various colours may be appropriate in areas of later burials
- Grave plots can be marked by simple stone kerbing, low fencing, or have no surrounds. Ledgers and grave tops can be used within surrounds. These elements should be traditional in form and materials, and similar to those existing in the immediate area. New high cast metal fencing is not appropriate

8.2 Reuse of Grave Plots

The issue of how to approach the reuse of graves of the long-dead and the sites of possibly more recent but unacknowledged burials is contentious. The reuse of significant grave sites is generally contrary to the conservation of the cultural significance of any historic cemetery. New interment should not occur in grave sites where historic burials have occurred and where these are marked by significant monuments, despite the grave site lease having expired.

The retention of significant monuments within the cemetery due to their heritage value usually precludes reuse, unless the elements of the original monumentation are retained, and the new interment is discreetly marked. This should be by a separate foot-stone in an appropriate colour and design.

8.3 New Monumentation/Memorialisation

Additional interments can and will occur in family plots, but new memorialisation of the grave should be through carefully considered additional inscription on the existing monument separate from and below the original (or possibly on another face of the monument) or by the use of a separate new tablet at the base of the existing monument or at the foot of the grave, inside the grave surround. The new tablets should be complementary in material to the existing headstone. Attaching metal plaques to old headstones as a way of marking new interments is not recommended.

New interments in graves which already have monuments or headstones but where the grant has been purchased by a new lessee not related to the original lease holder should be marked by a simple new tablet at the foot of the grave in complementary material.

8.4 Introduction of New Structures

Columbaria, lawn cemetery areas, historic markers and memorial areas for still-born burials, and other structures for shade and shelter are often incorporated into cemeteries.

New structures should be carefully considered in historic cemeteries. Their design, location and materials must not intrude on the historic cemetery landscape. If such elements are required within historic cemeteries the structure should be carefully designed to complement the historic character. This can be done successfully by repeating the existing form or details of structures already in place or by using a very simple modern structure.

The trend to lawned sections in cemeteries is a result of increased costs and reduced resources. These areas are usually not appropriate in historic cemeteries and should not be used to replace historic areas of larger cemeteries. If lawned areas are unavoidable they must be designed so that they do not disturb the established plan and layout of burial allotments, but rather continue the plan. Preferably, they should be located outside the original cemetery plan boundaries, or in discrete areas within the cemetery.



9.0 INTERPRETATION AND PROMOTION

9.1 Signage and Directions

Historical markers are tools that will increase public awareness of individual or institutional associations with the cemetery. Some cemeteries do not require signs, but visitors to larger cemeteries usually benefit from some help in finding significant areas and graves.

There are two types of markers:

- To provide information along a specific trail through the cemetery, often with additional information at significant grave sites
- To actually locate and mark significant unmarked burials

The design of such markers needs to be carefully considered so that the signs themselves are useful, but do not compromise the historic and aesthetic qualities of the graves and the cemetery as a whole. A system of small, discreetly located signs or numbers is best, but of course these should be legible. Often some design advice is valuable at the outset if marker signs are being considered. A Conservation Management Plan should make recommendations for signage in any historic cemetery.

9.2 Information for Visitors

A well designed easily followed pamphlet or annotated map of the cemetery may reduce the need for a large number of signs or markers. However, pamphlets can cause litter. A large scale map of the cemetery at the entrance may suffice with contact telephone number for further information.

9.3 Friends Groups/Volunteers

Any cemetery needs friends

Historic cemeteries can become an integral part of the community. Awareness and education are among the best ways to guarantee the conservation of a cemetery and are a valuable security strategy. Friends groups, or a subcommittee of the local Historical Society or National Trust branch, are extremely useful for providing volunteers to care for historic cemeteries.

These groups should be actively supported by local councils or authorities responsible for the management of historic cemeteries, such as assistance with materials, equipment, funding or even manpower for heavy work. The responsible authority should also be sure that appropriate insurance and training is provided for all volunteer workers

Friends groups can develop a pro-active program which will bring the value of the cemetery to the notice of their community. Some suggestions are:

- Stage periodic clean up days with specific tasks based on the recommendations of these guidelines or a Conservation Management Plan
- Run short regular articles in the local newspaper about the lives of individuals or families buried in the cemetery
- Involve local school children in the cemetery by offering suggestions for teaching units based on the cemetery. These could be based on community history, including infant mortality, local epidemics or catastrophic events, or on local flora and habitat. Headstone designs, for instance, could be used as the basis for an Art study unit which could be integrated with English creative writing, social studies or history units

10.0 SAFETY AND SECURITY

10.1 Security

A well cared for cemetery is less likely to attract vandalism and random acts of destruction than one which is in a dilapidated state. Managers of an urban cemetery could consider the following:

- Being well lit at night will deter vandals
- Security fencing - Fencing which allows viewing of the cemetery, rather than high, solid fencing, is appropriate to create a sense of awareness and deter vandals from entering
- Caretakers on site or close to the cemetery can be an effective security process
- A 'cemetery watch' system can be established if located close to settlement or in a residential area. It is also sensible to alert local police to the significance of the cemetery and ask them to add the cemetery to their patrol program

10.2 Public Safety

The safety of visitors to any cemetery must be ensured by the managing authority.

Large unstable monuments, or grave sites which have subsided, should be fenced off to ensure that there is no risk to public safety and no one is injured. This is better than dismantling large structures prior to determining the conservation requirements.

Any work to be undertaken by volunteers should be carefully assessed for risk, and an appropriate volunteer management strategy should be in place which meets Occupational Health and Safety requirements.

All volunteers should be carefully briefed on the risks of working in historic graveyards and informed of the processes in place for managing groups or individuals.

PERSONAL SAFETY WHEN WORKING IN AN HISTORIC CEMETERY

There are a number of hazards to look out for when walking or doing work around cemeteries. As long as adequate precautions are taken accidents can generally be avoided.

Do not walk on grave sites - Soil overlying graves may gradually subside over time and may collapse when walked on

Do not lean on headstones or monuments - As a result of soil collapse, monumentation may become unstable. If monuments collapse they may be irreparably damaged as well as causing serious personal injury

Do not use whipper snippers - Whipper snippers can accidentally come into contact with fragile stone, metal or other loose objects creating flying debris. As well as potentially damaging grave monumentation, they can cause serious personal injury

Snakes - Snakes are a part of Australia's native fauna and may naturally belong in the areas of indigenous vegetation within the cemetery. Snakes are shy by nature and will only attack when threatened. Take care, however, especially in warm weather and where work is being undertaken in areas of dense, long grass that have been unattended for some time. Avoid killing snakes wherever possible

10.3 Fire Precautions

If a cemetery is overgrown and not maintained it may be at risk of damage by fire. Grounds should be kept clear of flammable material to reduce the fuel load in the event of fire. If a fire break is created this should be outside the perimeter of the cemetery, to avoid any damage to grave sites. An emergency plan which includes emergency contacts, training for volunteers and links to Council services should be prepared.

No rubbish should be burned off within or close to a cemetery, as this could cause an uncontrolled and damaging fire in the cemetery itself.



11.0 FUNDING

11.1 SA Heritage Cemetery Fund

Funding is available through the [Heritage Cemetery Fund](#) administered by the Department for Environment and Heritage. Grants of up to \$2,000, on a dollar for dollar basis, are available to those with an interest in the maintenance and management of small historic cemeteries or individual graves.

11.2 History Trust of SA

The History Trust has an annual grants program which could be used for funding for historical research and interpretation of cemeteries

11.3 The Australian Government Envirofund

The Australian Government Envirofund is for individuals, incorporated community groups and sponsored unincorporated community groups to undertake small projects aimed at conserving biodiversity and promoting sustainable resource use. The Australian Government Envirofund will help groups to carry out on-ground and other actions to target local problems.

Applications can be made to the Australian Government Envirofund for project funding of up to \$30,000.

11.4 Non-Government Sources

There are other non-Government methods of raising funds available to Friends Groups if they wish to undertake conservation works. These include:

- Forming a non profit cemetery organisation
- Soliciting donations for specific projects from the descendants of the deceased buried in the cemetery
- Requesting help from Council and other sources for allocation of funds, equipment or personnel to maintain cemeteries for health and safety reasons
- Requesting donations from associated businesses including funeral directors and monument companies who may wish to 'give back to the community'
- Using the tax free donation process available through the creation of a National Trust Appeal

12.0 RECORDS, REFERENCES AND SOURCES

12.1 Cemetery Conservation Records

All work undertaken within a cemetery should be documented and become part of the records of the place, including grave site identification, conservation of monuments and any landscape work. The managing authority should be responsible for the updating and storage of these records and should make them available for research.

12.2 Cemetery Conservation Publications

Australian Council of National Trusts, *National Guidelines for the Conservation of Cemeteries*, Canberra, 1996

Lavelle, S, *Cemeteries: Guidelines for their Care and Conservation*, Department of Planning, Heritage Council of NSW, Sydney, 1992

Maxwell, I, Nanda, R & Urquhart, D, *Conservation of Historic Graveyards*, Guide for Practitioners 2, Historic Scotland, Edinburgh, 2001

Mayer, L R, *The Care of Old Cemeteries and Gravestones*, Association for Gravestone Studies, Fitchbury, MA, 1980

National Trust of Australia (NSW), *Cemeteries: a National Trust policy paper*, Sydney, 1985
Revised in 2002 and published as *Guidelines for Cemetery Conservation*
<http://www.nsw.nationaltrust.org.au/cemsguidelines.html>

Sagazio, C (ed) *Conserving our Cemeteries: an Illustrated and Annotated Guide Based on the ACNT National Guidelines for the Conservation of Cemeteries*, Melbourne, 2003

Young, DA, *Rising damp and salt attack*, South Australian Department of Environment and Natural Resources, and the City of Adelaide, Heritage Conservation, 1995

12.3 Technical Information

Australian Standard 4204-1994 *Headstones and Cemetery Monuments*

Australia ICOMOS, *The Burra Charter: The Australia ICOMOS Charter for Places of Cultural Significance*, 1999, with associated *Guidelines and Code on the Ethics of Co-existence*, Melbourne, 2000 www.icomos.org/australia/

Young, David A, *Preliminary Guide to Caring for Monuments and Grave Sites*, West Terrace Cemetery Adelaide, 1997

Department of the Environment and Heritage, *Protecting Natural Heritage: using the Australian Natural Heritage Charter*, 2nd Edition 2002

SA Government, *Forests and Woodlands of the Adelaide Plains in 1836, a native vegetation planting guide*. Poster with easy to use information on native plant associations for localities in the Adelaide Plains area. Based on:

Kraehenbuel, Darrell N., *Pre-European Vegetation of Adelaide*, 1996, Nature Conservation Society of Australia, Inc. Adelaide.

Robertson, Meg, *Stop Bushland Weeds: A Guide to Successful Weeding in South Australia's Bushland*, Revised Edition Oct 2000, Nature Conservation Society of Australia, Inc. Adelaide – Weed control in native bush sites

Muyt, Adam, *Bush Invaders of South East Australia*, 2001, R.G.

F.G. Richardson– *Weed control in native bush sites*

Prescott, Ann, *It's Blue With Five Petals*, Revised Edition 1994, Ann Prescott - Native plant identification

Planning SA, Fact Sheet: *Information about protecting Significant Urban Trees*, July 2003 Provides answers to the most frequently asked questions relating to the Significant Tree legislation and its implications. <http://www.planning.sa.gov.au/pub-pdf/486p.pdf>

Australian Heritage Commission, *Protecting Natural Heritage*, 2000

12.4 Relevant Legislation

Local Government Act 1934 Regulations, No 113 of 1995 covers provisions for Cemetery Management

National Parks and Wildlife Act 1972: Schedules of threatened plant and animal species

Native Vegetation Act 1991: Covers legislation with regard to clearance of native vegetation.

Development Act 1993, Regulation 6A (Significant Trees) of the Development Regulations 1993

Heritage Act 1993 sets parameters for State Heritage Registered cemeteries

Health Act covers health requirements for burials and cemeteries

12.5 Websites:

State Inventory of Heritage Places	www.environment.sa.gov.au/heritage/index.html
National Trust of SA	www.nationaltrustsa.org.au
Environment Australia	www.ea.gov.au/
Australian Heritage Council	www.dhc.gov.au/ www.dhc.gov.au/publications/pnh/
History Trust of SA	www.history.sa.gov.au
ICOMOS	www.icomos.org
Natural Heritage Trust	www.nht.gov.au
Australian Network for Plant Conservation	www.anbg.gov.au/anpc/
Bushcare	www.environment.gov.au/bg/bushcare
Conservation Council of South Australia	www.ccsa.asn.au
Nature Conservation Society of South Australia	www.ncssa.asn.au
Invasive garden plants	www.agric.wa.gov.au
Proclaimed Plants in South Australia	www.chariot.net.au/~adplains/plants.htm
Planning SA (Significant trees)	www.planning.sa.gov.au/pub-pdf/486p.pdf

There are a range of international organisations involved the recording and conservation of cemeteries. Many of their web sites contain useful and interesting information.

Texas Historical Commission	www.thc.state.tx.us
Historic Scotland	www.historic-scotland.gov.uk
English Heritage	www.english-heritage.org.uk
Ministry of Culture, Ontario, Canada	www.culture.gov.on.ca
The Association for Gravestone Studies, USA	www.gravestonestudies.org

13.0 GLOSSARY

13.1 General Terms

Axial: a layout, plan or design with an axis of symmetry

Cemetery: a place where the dead are buried

Crematorium: a building in which corpses are cremated

Crypt: a chamber or vault used as a burial place for multiple interments

Curvilinear: a cemetery plan or design characterised by curved lines. 'Gardenesque' style usually has a curvilinear layout

Edwardian: of, or relating to, the period of the reign of King Edward, 1901-1910, generally covers similar period as Federation in Australian history (c1895-c1915)

Gardenesque: a landscape design style characterised by garden-like open spaces and often curvilinear paths and plantings

Gothic Revival: a nineteenth century revival of the medieval gothic style of architecture and art. It is characterised by asymmetry and steep verticality of structural and decorative elements, eg, pointed arches, spires and pitched roofs. Some grave monuments use this style

Grave furniture: ornamental items that are supplementary to the principal memorial on grave plots, eg, urns, vases and grave surrounds, etc

Grave stones: markers within the grave site and these include headstones, footstones or sculpture

Grave surrounds: grave surrounds are a form of fencing around the burial plot and can be made of stone kerbing, cast or wrought iron, rolled steel or timber, usually pickets

Grid: a design or pattern of regularly spaced horizontal and vertical lines crossed at right angles to each other. (This is the most common cemetery plan)

Headstone shapes: there are a variety of headstone shapes including upright slabs or headstones, crosses, pillars, obelisks, sculptures, horizontal slabs, other miscellaneous forms

Immortelles: funerary ornaments, usually in the form of a floral wreath or posy, made of ceramic and metal, and enclosed in a glass case (usually round)

Monuments: all built features on a grave

Necropolis: city of the dead; a large cemetery

Neo-Classicism: an early nineteenth century style modelled on Ancient Greek and Roman art and architecture. It is characterised by regularity, simplicity, balance and proportion of form. Most grave monuments use this style

Obelisk: tall pillar, square in cross section, tapering upward, and with a pyramidal top

Pedestal: layers of base built up on top of the plinth

Plinth: the base of a headstone which is in contact with the ground

Victorian: of, or relating to, the period of the reign of Queen Victoria, 1837-1901

13.2 Terms for Describing Grave Site Condition

Condition of Carving -

Mint: carving is in perfect condition, as though it was just carved

Clear but worn: carving shows some wear but legibility is not affected

Mostly readable: carving is difficult to read without directing light across the surface with the aid of a mirror or a flashlight

Illegible: none of the carving can be read

Traces: parts of the carving are visible but difficult to read or to determine the whole design

Underground: stone is laying face down or buried so carving cannot be read

Overall Condition -

Biological activity: lichen, mould, or mildew found on the surface

Blistering/flaking/scaling/powdering: small or isolated areas are missing or surface of the stone is loose

Cracked: stone is cracked but not broken into separate parts

Delaminating: the stone, usually slate, is splitting off in layers

Erosion: sections of the stone are worn off, usually from wind or water

Fragmented: sections of the stone are broken into many parts

Graffiti: designs not part of the original design are drawn, painted, sprayed or scratched on the stone

Losses: parts of the stone are missing, such as a finial (terminating detail on the top of the gravestone)

Open joints: the mortar in the mortar joints is missing

Soiled: the surface is covered with dirt but can be easily washed off with water

Stained: the surface exhibits stains that cannot be easily removed with water

Tilted/fallen/sunken: the stone is not in its original alignment or is partly below the surface

Previous Visible Repairs -

Adhesive repairs: repairs to the stone with epoxy or some other adhesive have not been cleaned off the surface following repairs (may have turned a butterscotch colour because of ultraviolet light)

Coatings: used on some stones to extend the life of the material; however, most coatings are not appropriate (limestone and marble with a shiny or milky finish probably have a coating on them)

Iron pins/braces: improper method to secure pieces of stone together or to support the stone which usually results in the iron rusting and staining the stone

Portland cement: hard grey concrete improperly used to repair gravestones or encase fragments

Replacement: total replacement of the original stone which can be determined by the date of death or the newness of the stone

APPENDIX 1: EXAMPLE OF GRAVE SITE RECORD

Location: Area: A **Row:** A **Number:** 11 & 12 (430, 445)
Photograph: (Date taken: 17/5/02) (2 sets of inscriptions)

Inscription and Biographical Information:

In loving memory of Sarah Jane, daughter of the late Samuel Thomas Nesbit who died August 29, 1901, also Wilfred Aubrey Knowle, grandson of above, accidentally drowned at Terowie, February 25th 1928 aged 12 years - safe in the arms of Jesus, also Samuel Thomas Nesbit who died January 29th 1903 and Sarah Jane, the wife of the above who died July 6th 1905 - God alone who knoweth best and taketh our loved ones home to rest, also Mary, oldest daughter of above, died June 4th 1924 aged 43 years - loved in life, treasured in death, a beautiful memory is all we have left.



Description of Monument/Site:

Kerbing	- recent concrete footings and kerb
Railing	- painted wrought iron, approx 400mm high
Grave topping	- coarse aggregate gravel with 4 marble blocks & ceramic flowers, blocks labelled Mum, Dad, Mary & Sarah
Base of headstone	- two steps of marble
Headstone/Monument	- white marble cross with dove
Lettering/Inscription	- leaded letters - refer photo
General setting/planting	- well cared for

Conservation Recommendations:

Kerbing & base	- in good condition
Railing	- will require repainting, but galvanised wrought iron appears in good condition
Grave topping	- good condition, some moss growth, but gravel intact, sits within a galvanised tray
Base of headstone	- in good condition, should only be brushed carefully, may require some biocide washing to remove moss
Headstone/Monument	- in good condition, cleaning as above
Lettering/Inscription	- in good condition - no conservation required
General setting/planting	- fine



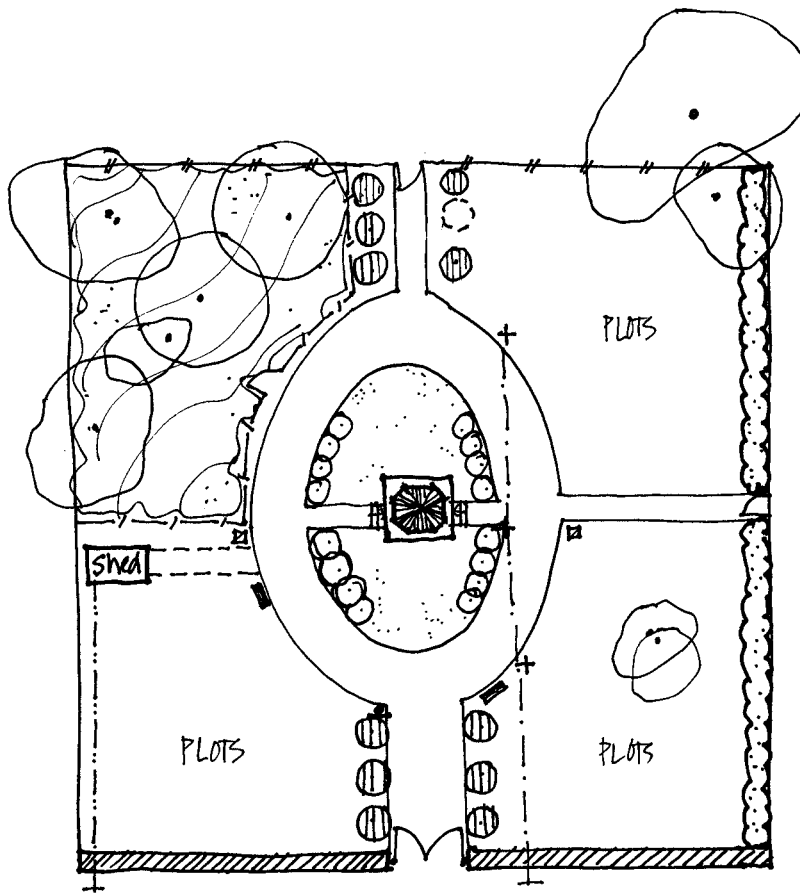

















APPENDIX 2: TYPICAL LANDSCAPE PLAN



0 5 10 metres
SCALE



LEGEND

- | | | | |
|---|-------------------|---|--------------------------|
|  | tree |  | road/path/steps up |
|  | conifer |  | track |
|  | missing tree |  | mown grass |
|  | ornamental shrubs |  | native vegetation |
|  | hedge |  | power line (underground) |
|  | stone wall |  | water supply |
|  | iron fence |  | tap |
|  | post & wire fence |  | seat |
|  | gate |  | bin |
|  | sign |  | shelter |

APPENDIX 4: TYPICAL VEGETATION MANAGEMENT RECORD

Vegetation Management Record

Cemetery		Date	
REVEGETATION AREA			
Successful Species	Year	planted	
Unsuccessful Species	Year	planted	
WEED CONTROL			
Major Species	Location	Control Method	Comments
NEW WEED INFESTATION			
Major Species	Location	Control Method	Comments
SOIL EROSION			
Location	Control Method		Comments

REPAIR OF BROKEN BASE

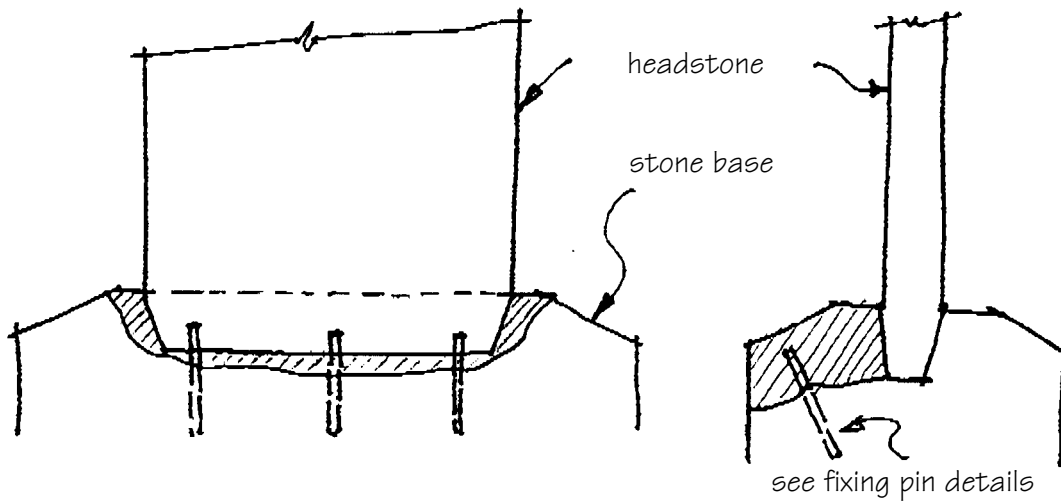

Repair base as follows:

- if broken off piece is available, pin back as shown.
- if broken off piece is missing, scabble exposed face, insert pins and build up using lime rich concrete to match original profile.
- pin as detailed.

Note: clean up excess adhesive as soon as possible (to manufacturer's recommendation)

APPENDIX 6: HERITAGE ACT AND DEVELOPMENT ACT CRITERIA

State Heritage Criteria

Heritage Act 1993, Part 4 Registration of Places, Division 1 Criteria for Registration, Section 16 Heritage Value

- (a) it demonstrates important aspects of the evolution or pattern of the State's history; or
- (b) it has rare, uncommon or endangered qualities that are of cultural significance; or
- (c) it may yield information that will contribute to an understanding of the State's history, including its natural history; or
- (d) it is an outstanding representative of a particular class of places of cultural significance; or
- (e) it demonstrates a high degree of creative, aesthetic or technical accomplishment or is an outstanding representative of particularly construction techniques or design characteristics; or
- (f) it has strong cultural or spiritual associations for the community or a group within it; or
- (g) it has a special association with the life or work of a person or organisation or an event of historical importance.

Local Heritage Criteria

Development Act 1993, Part 3 Planning Schemes, Division 2 Development Plans, Subdivision 1 Creation of Plans, Section 23(4) Development Plans

- (a) it displays historical, economic or social themes that are of importance to the local area; or
- (b) it represents customs or ways of life that are characteristic of the local area; or
- (c) it has played an important part in the lives of local residents; or
- (d) it displays aesthetic merit, design characteristics or construction techniques of significance to the local area; or
- (e) it is associated with a notable personality or event; or
- (f) it is a notable landmark in the area.
- (g) in the case of a tree - it is of special historical or social significance or importance within the local area.

APPENDIX 7: TOOLS AND MATERIALS FOR GRAVESTONE CLEANING PROJECTS

Adapted from:

[The Association for Gravestone Studies](#), Frequently Asked Questions, US, 2001

STONE TYPES

Marble and Limestone

- Water
- Non-ionic detergent (Foto-Flo-Kodak product)
- Dishwashing detergent for sensitive skin
- Household ammonia (requires water hose for rinsing and Hydrion paper test strips for pH testing)
- Calcium Hypochlorite (HTH) for biological growth retardation (requires water hose for rinsing and Hydrion paper test strips for pH testing)

Slate and sandstone

- Water
- Non-ionic detergent (Foto-Flo-Kodak product)

GENERAL CLEANING

- Good water supply
- Non-ionic detergent (Photo-Flo-Kodak product) - 25ml per 20 litres
- Ammonia - 250ml per 5 litres (for marble only)
- Calcium Hypochlorite (granular) - 25g per 5 litres
- Assortment of brushes (NOT WIRE) of varying stiffness
- Toothbrushes (firm), sponges
- Scrapers - craft sticks, plastic scrapers, wooden skewers.

POULTICE SOFTENING

- Kaolin/porcelain clay (dry)
- Glycerine (use 50/50 mixture)
- Water
- Glad Wrap and heavy plastic for wrapping
- Tape/string to secure plastic
- Scrapers - plastic and wood

DO NOT USE

- Wire brushes, metal instruments, abrasive pads (Scotchbrite, Brillo, Steel wool)
- Acid or acidic cleaners (especially on marble or limestone!) or liquid chlorine (should only be used by conservators with property training on non-calcareous stone)
- Household cleaners: soap (Lux), strong detergents (liquid or powder), Borax, Chlorox, TSP, Calgon, Ajax, Jif, Gumption (or any other abrasive cleaner)

REMEMBER:

The use of improper cleaning materials and practices can cause serious and irreparable damage to gravestones. Make sure the stone is stable before attempting to clean it - no flaking, delaminating, or other deterioration.

APPENDIX 8: SYMBOLISM IN CEMETERIES

Many symbols were used on monuments, some of which had several meanings. Below is a list of some of the most common found in South Australian cemeteries:

1. Symbols

All-seeing eye	Omnipresence of God
Altar	Sacrifice, worship, thanksgiving and remembrance
Angel	Messenger of God to man
Anchor	Hope, safety or security
Arch	Triumph over death
Archer	Death
Arrow	Mortality
Axe	Martial themes
Bible	Charity or piety
Book	Learning, scholarship, prayer or trade of a writer or bookseller
Broken Chains	Links of love with a family broken in death
Broken Circle	Life has ended
Broken Column	Life cut off by death
Candle being snuffed	Loss of life
Cenotaph	Mourning
Chalice	represents the Sacraments
Cherub	Innocence
Circle	Eternity
Circle with Wings	Immortality
Cloud	Hand from Heaven
Coffin	Mortality
Column	Sky, God and deity
Compass	Divine measuring and dividing of the world, indicative of architects and surveyors
Crescent	Probably the grave of a Muslim
Cross	Christ's redemption of humanity from sin. Faith and belief in God
Crown	Reward and glory, sovereignty, victory
Crown of Thorns	Passion of Christ
Dawn (sunrise)	Resurrection, reunion in Heaven
Dove	The Spirit of God, love, Spiritual Peace or renewed life
Dragon	Evil and the serpent
Eagle	Liberty (military)
Eye of God	All seeing
Flame (fire)	Light, life and eternity, creation and destruction
Fleur de Lis	Life
Flower with broken stem	Life has ended
Griffon	Power, a guardian of treasure and watchfulness
Grim Reaper	Death personified
Hand	Emerging from a heavenly cloud symbolises a blessing from God. A heart in the palm means charity. Left hand is the Devil's.
Hands (clasped)	Reunited in Heaven (the cuffs are usually those of a male and female and are used on husband and wife monuments)
Hands (pair)	Prayer and/or supplication
Harp	Praise to God
Heart	Piety, love or charity
Hour glass	Time and its passing
Hour glass and scythe	The certainty of death
Lamb	Innocence of children or sacrificial lamb of God

Menorah	Emblem of Judaism
Obelisk	Eternal life, fertility, regeneration and resurrection
Obelisk (broken)	Life cut short
Open Book	Perfect knowledge
Ring	Completeness and perfection
Rod or Staff	Comfort
Scallop Shell	Pilgrimage
Scroll	Life and time, honour and commemoration
Scythe	Death
Spade	Death
Skeleton/skull	Death
Serpents	Trampled in triumph over sin and death, or eat their tails in the old Celtic symbol of eternity
Shell	Life and resurrection
Spiral	Progressive development and movement
Spire	Religious aspiration
Star of David (Mogen David)	International symbol of Judaism
Torch	Immortality
Triangle	The Trinity
Urn	Death and mourning
Urn with flame	Undying remembrance
Vase	Death and mourning

2. *Plants*

Flowers and plants were adopted as symbols of death, mourning and hope, and were used to decorate embroidery, jewellery, coffin furniture, monuments and a host of other items associated with funerals. Dozens of individual plants had associated symbols such as those below:

Acanthus	Heavenly gardens
Acorn	Strength, glory and honour
Aloe	Affliction/Grief
Anemone	Forsaken, blossoming and early death
Amaranth	Immortality
Apples	Forbidden fruit, fruit of salvation and sweetness in love
Asphodel	My regret follows you to the grave
Balm	Sympathy
Bay leaf	I change not in death
Bluebell	Constancy
Clover	Think of me
Convolvulus	Extinguished hopes or eternal sleep
Cypress	Death/mourning
Daisy	Innocence
Fern	Sincerity, humility
Forget-me-not	True love/remembrance
Geranium	Melancholy
Grapes or grape vine	Christ's miracles and abundance
Honeysuckle	Bonds of love or Resurrection
Ivy	Security/fidelity, loyalty, patience, immortality and bonding
Laurel	Victory and achievement in arts, glory, reward
Lily	Purity, chastity and virginity
Marigold	Grief or despair
Mistletoe	Protection, veneration and healing power
Morning Glory	The beginning of Life
Oak tree	Life, steadfastness, strength, glory, honour, durability

Olive	Peace and security
Palm Branch	Victory and Rejoicing
Pansy	Thought
Periwinkle	Memories
Pomegranate	Fertility
Poppy (red)	Consolation, eternal sleep
Rose (thornless)	Innocence and paradise
Rosemary	Remembrance
Shamrock	Symbol of Ireland - used on Irish Catholic monuments
Snowdrop	Hope
Sunflower	Gratitude and affectionate remembrance, brightness
Thistle	Remembrance also symbol of Scotland - used on Scots graves
Vine	Christian faith
Violet	Faithfulness
Wheat	Riches or the continuation of life
Willow	Mourning
Yew	Sorrow

3. Letters

AO	AO or Alpha and Omega refer to the beginning and the end, and are often shown with the book of life
IHSX	Iota, epsilon and sigma were first three letters of 'Jesus' in Greek, In 'Hoc Signo' was Latin for 'In this sign you will conquer'. Today it means 'Jesus Hominum Salvator' (Jesus Saviour of Men)
T	The Greek T, or tau, is the initial of Theos (God) and is also the Egyptian hieroglyphic for life
TNZBH	Hebrew symbol for 'may their soul be bound up in the bond of eternal life'
XP or PX	The letters XP, or Chi-Rho are the first two Greek letters in the name 'Christos' and refer to being buried under Christ. Today the letters may be reversed as PX to represent 'pax' or 'peace'

APPENDIX 9: PLANTS SUITABLE FOR SOUTH AUSTRALIAN CEMETERIES

Adapted from:

Robert Nicol, *Cemeteries of South Australia*, Department of Environment and Planning, 1988
 Celestina Sagazio ed. *Conserving Our Cemeteries*, National Trust of Australia (Victoria), Melbourne, 2003

An enormous variety of soil and climatic conditions may be found when dealing with South Australian cemeteries. Local knowledge will therefore be an important element of any planting scheme. Within that limitation, however, it is possible to produce a general list of plants which can be found in South Australian cemeteries or for the use of which evidence is available. A general caution must be included that some plant species adapt well to particular soils and climates and may themselves become a pest. A good example is hawthorn, which whilst creating a picturesque scene, has over-run some cemeteries in areas like the Adelaide Hills and the Clare Valley. Olives and Privets may create similar problems.

Trees

Natives: (Native plants are normally found as natural stands or in perimeter plantations, but also at times as specimen trees).

*	native to South Australia
#	potential weed species
##	Proclaimed Plant in South Australia
* <i>Acacia</i> various species	Wattles
<i>Acacia ulicifolia</i>	Juniper Wattle, Prickly Moses
<i>Acmena smithii</i>	Lilly Pilly
<i>Agonis flexuosa</i>	Willow Myrtle, Peppermint Tree
* <i>Allocasuarina verticillata</i>	Drooping She Oak, Mountain Oak
<i>Araucaria bidwillii</i>	Bunya Bunya Pine
<i>Araucaria cunninghamii</i>	Hoop Pine
<i>Araucaria heterophylla</i>	Norfolk Island Pine
<i>Brachychiton populneus</i>	Kurrajong
<i>Callistemon citrinus</i>	Lemon Scented Bottlebrush
* <i>Callitris gracilis</i> syn. <i>preissii</i>	Rottneest Island Pine, Slender Cypress Pine
<i>Casuarina distyla</i>	She Oak
<i>Eucalyptus bicostata</i>	Eurabbie, Southern Blue Gum
* <i>Eucalyptus camaldulensis</i>	River Red Gum
<i>Eucalyptus ficifolia</i>	Scarlet Flowering Gum
* <i>Eucalyptus leucoxydon</i>	Yellow Gum
<i>Eucalyptus nicholii</i>	Peppermint Gum
<i>Eucalyptus rossii</i>	Scribbly Gum
* <i>Eucalyptus rugosa</i>	Kingscote Mallee
<i>Langunaria pattersonii</i>	Norfolk Island Hibiscus, Pyramid Tree
<i>Tristaniopsis laurina</i>	Weeping Box, Water Gum

Exotics:

<i>Abies nordmanniana</i>	Caucasian Fir
<i>Abies pinsapo</i>	Spanish Fir
<i>Arbutus unedo</i>	Irish Strawberry Tree
<i>Calocedrus decurrens</i>	Californian Incense Cedar
<i>Cedrus atlantica</i>	Atlas Cedar
<i>Chamaecyparis funebris</i>	Chinese Mourning Cypress
<i>Chamaecyparis lawsoniana</i>	Lawson Cypress
<i>Cinnamomum camphora</i>	Camphor Laurel
<i>Cupressus glabra</i>	Arizona Cypress
<i>Cupressus lusitanica</i>	Mexican Cypress, Cedar of Goa
<i>Cupressus macrocarpa</i>	Monterey Cypress
<i>Cupressus sempervirens</i>	Italian Cypress, Mediterranean Cypress
<i>Ficus macrophylla</i>	Moreton Bay Fig
<i>Morus alba</i>	White Mulberry
<i>Pinus canariensis</i>	Canary Island Pine
# <i>Pinus halepensis</i>	Aleppo Pine
<i>Pinus pinea</i>	Italian Stone Pine
# <i>Pinus radiata</i>	Radiata Pine, Monterey Pine
<i>Prunus laurocerasus</i>	Cherry Laurel
<i>Prunus lusitanica</i>	Portuguese Laurel
<i>Quercus ilex</i>	Holm Oak, Holly Oak
<i>Quercus robur</i>	English Oak
## <i>Salix babylonica</i>	Weeping Willow
# <i>Schinus molle</i>	Peppercorn Tree
<i>Taxus baccata</i>	Yew
<i>Ulmus procera</i>	English Elm

Palms:

<i>Phoenix canariensis</i>	Canary Island Date Palm
<i>Phoenix reclinata</i>	Senegal Date Palm
<i>Washingtonia filifera</i>	Fan Palm

Shrubs**Natives:**

<i>Acacia</i> var. sp.	
* <i>Acacia iteaphylla</i>	Flinders Range Wattle
* <i>Westringia fruticosa</i>	Native Rosemary

Exotics:

<i>Buxus sempervirens</i>	English Box
<i>Carissa spectabilis</i>	Winter Sweet
<i>Coleonema album</i>	White Diosma

<i>Coleonema pulchrum</i>	Pink Diosma
# <i>Cotoneaster serotinus</i>	Cotoneaster
<i>Elaeagnus angustifolia</i>	Russian Olive
<i>Euonymus japonica</i>	Evergreen Spindle Tree
<i>Hebe</i> sp.	Veronica
<i>Lavandula angustifolia</i>	English Lavender
<i>Lavandula dentata</i>	French Lavender
<i>Lavandula spicata</i>	Lavender
# <i>Ligustrum ovalifolium</i>	Golden Privet
# <i>Ligustrum vulgare</i>	Glossy Privet
<i>Photinia glabra</i>	Photinia
<i>Photinia serrulata</i>	Chinese Hawthorn
<i>Rhaphiolepis indica</i>	Indian Hawthorn
<i>Rosmarinus officinalis</i>	Rosemary
<i>Tecomaria capensis</i>	Tecoma, Fire Flower
<i>Viburnum tinus</i>	Laurustinus

Roses

A variety of nineteenth and early twentieth century roses are now available and a selection of those appropriate for cemeteries is listed below. It should be noted that Roses are not traditionally widely grown in South Australian cemeteries. From a maintenance perspective, either standard or miniature roses are preferred.

Climbing Roses:

White:	Cherokee Rose (<i>Rosa laevigata</i>) Félicité et Perpétue Rambling Rector Silver Moon
Cream:	Albéric Barbier Devoniensis Fortuniana Mme Alfred Carrière
Yellow	Banksia Rose (<i>Rosa banksiae</i>) Gloire de Dijon Souvenir de Mme Boulet
Pink	American pillar Cécile Brünner Souvenir de la Malmaison
Red	Crimson Rambler Dortmund Ramona

Shrub Roses:

White	Alba Semi Plena Frau Karl Druschki Mme Hardy
Cream/Yellow	Desprez à Fleur Jaune Gabriel Noyelle Gardenia
Pink	Centifolia Muscosa La France May Queen Mme. Abel Chatenay Mme. Pierre Oger Mme Scipion Cochet
Mauve	Charles de Mills Magnifica
Red	Karl Herbst Prince Camile de Rohan

Climbers and Groundcovers:

<i>Hedera helix</i>	Ivy
<i>Lonicera fragrantissima</i>	Winter Honeysuckle
<i>Stachys officinalis</i>	Lamb's Ears
<i>Pelargonium sp.</i>	Pelargoniums and geraniums were popular grave plants
# <i>Vinca minor</i>	Periwinkle
# <i>Vinca major</i>	Periwinkle
<i>Wisteria sinensis</i>	Chinese wisteria

Bulbs, Tubers etc.:

<i>Agapanthus africanus</i>	Agapanthus
<i>Amaryllus belladonna</i>	Belladonna
<i>Freesia refracta</i>	Freesia
<i>Hippeastrum puniceum</i>	Hippeastrum, Barbados Lilly
<i>Iris sp.</i>	Iris
## <i>Watsonia sp.</i>	Watsonia

A wide variety of annual and small perennial plants and flowers are also suitable for cemetery planting, but it must be noted that the majority require consistent maintenance if they are to add to rather than detract from the appearance of the site.

REPAIR BROKEN GRAVESTONE

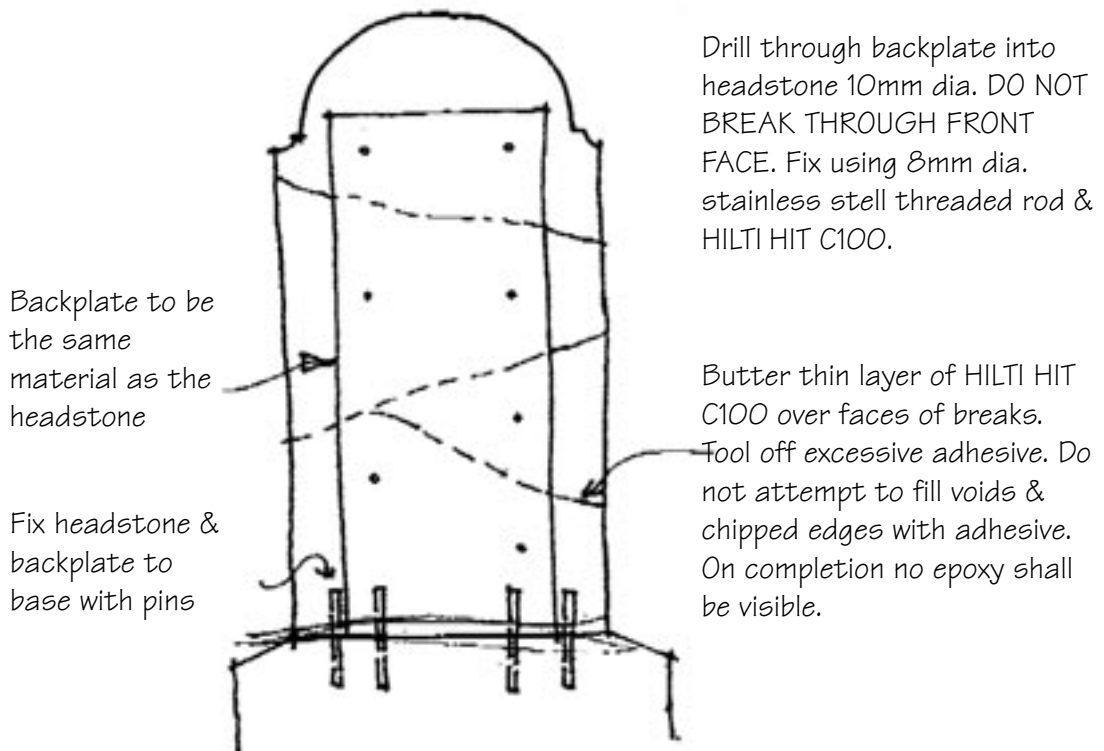
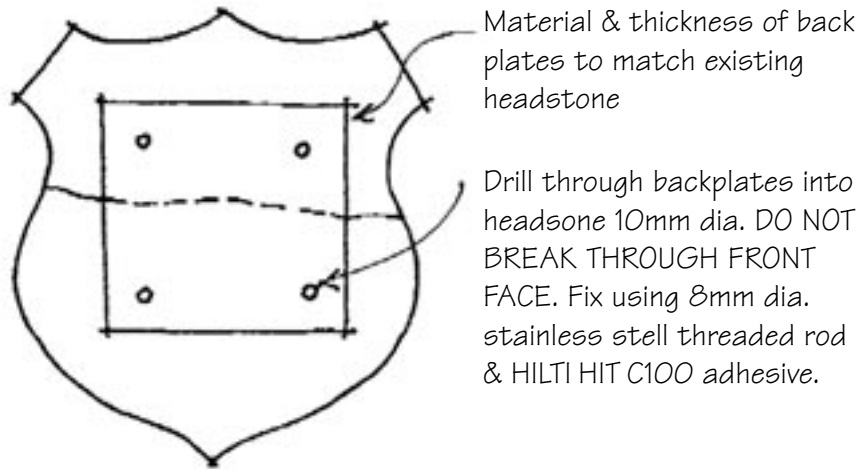

REPAIR TECHNIQUES USED AT WEST TERRACE CEMETERY
 Reproduced Courtesy of DAIS Heritage Unit

PINNING

Butter thin layer (epoxy) of HILTI HIT C100 over face of break. Tool off excessive adhesive.

NOTE: DO NOT attempt to fill chipped edges etc. with adhesive. On completion of repair no epoxy should be visible.

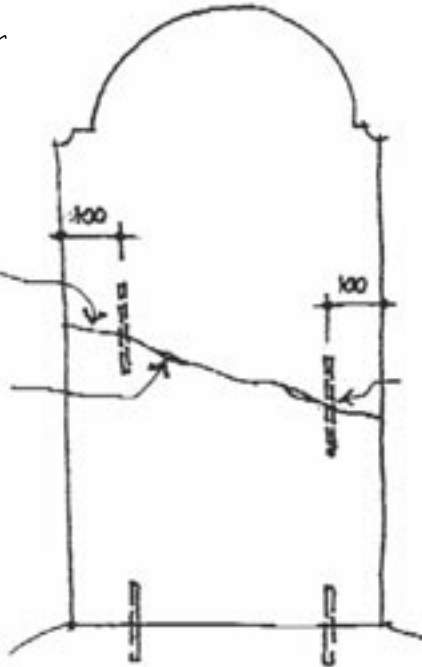

TYPICAL TABLET REPAIR DETAIL

For Face Joints

- Use acrylic resin for marble headstones, grind marble and mix with acrylic to make self coloured filler. Mask joints to ensure no epoxy is visible.

Stainless steel fixing pins. (refer to detail)

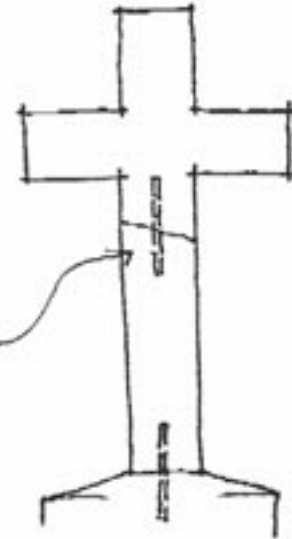

TYPICAL CROSS REPAIR DETAILS

8mm dia. stainless steel rod x 150mm long.

Drill 10mm dia. hole x 80 deep into each piece.

Fill holes with HILTI HIT C100 prior to inserting of threaded rod.



FIXING PIN DETAIL (typical)

Setting boards approx. 900 long (fabricated from timber)

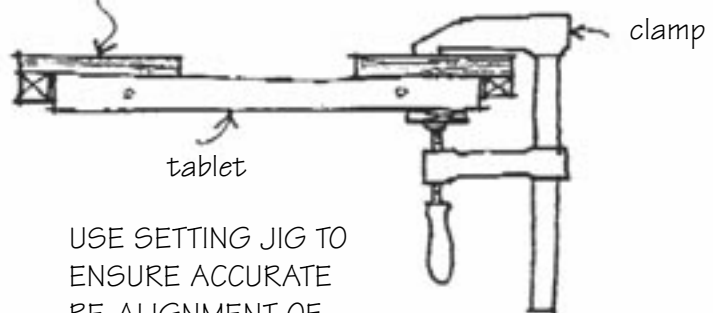

USE SETTING JIG TO ENSURE ACCURATE RE-ALIGNMENT OF FACES & EDGES

Clean up excess adhesives as soon as possible

HEADSTONE RESTORATION

REPAIR TECHNIQUES USED AT WEST TERRACE CEMETERY
Reproduced Courtesy of DAIS Heritage Unit